

UpRight

SL-26RT



SELF-PROPELLED LIFTS

- 10m (32ft) working height
- High platform capacity — 680kg (1,500lbs)
- Large platform area — 1.78 x 3.66m (70in. x 144in.)
- Rough terrain package — 4WD, oscillating front axle, flotation tyres
- Proportional drive and lift controls for smooth, precise operation
- Dual fuel or diesel power
- Optional Roll-out deck extension



Oscillating front axle for optimum rough terrain capability.

SL-26RT

SELF-PROPELLED LIFTS

FEATURES AND SPECIFICATIONS (All Models)

- Working height: 10m (32ft)
- Platform height: maximum: 8m (26ft)
minimum: 1.45m (57in.)
- Driveable height: 8m (26ft)
- Maximum platform capacity: 680kg (1,500lbs)
- Platform size: 1.78m x 3.66m (70in. x 144in.)
- Control system: proportional, single axis joystick with thumb rocker steering. Foot operated interlock switch
- Dimensions:
 - overall height: 2.55m (100.5in.)
 - overall length: 3.79m (149in.)
 - wheelbase: 2.54m (100in.)
 - overall width: 2.13m (84in.)
- Ground clearance: axle 200mm (7.75in.)
chassis 320mm (12.5in.)
- Turning radius (inside): 3.96m (13ft)
- Drive: four wheel with hydraulic motors
- Drive speeds: maximum 5.0kph (3.1mph)
with platform raised 0.8kph (0.5mph)
- Gradeability: 35%
- Front axle: oscillating with automatic lock-out cylinder
- Parking brake: spring applied, hydraulic released, multiple disc
- Guardrails: fold down with gate, 1.11m (43.5in.) high
- Toeboards: 150mm (6in.)
- Lift speed: raise 21 sec./lower 32 sec.
- Descent alarm ■ Hour meter
- Wiring for power at platform

OPTIONAL FEATURES

- 2000 watt / 110V AC generator
- Flashing amber beacon/horn
- 3 cylinder 24.5 HP water cooled Kubota Dual fuel engine
- Poly filled flotation tyres
- Roll-out deck extension — 1.0m (39")*

*Maximum capacity on deck extension is 226kg (500lbs)

FEATURES AND SPECIFICATIONS (Specific Models)

Item	Dual Fuel		Diesel	
Energy Source	20 HP Kohler Dual Fuel, 2 Cylinder, air cooled engine (gasoline/propane)		18 HP Kubota Diesel, 3 Cylinder, water cooled engine	
Weight	2,458kg	5,420 lbs	2,531 kg	5,580 lbs

Meets or exceeds applicable requirements of OSHA, ANSI A92.6 -1990 / DIN /BS and all International Regulations

Specifications subject to change without notice.

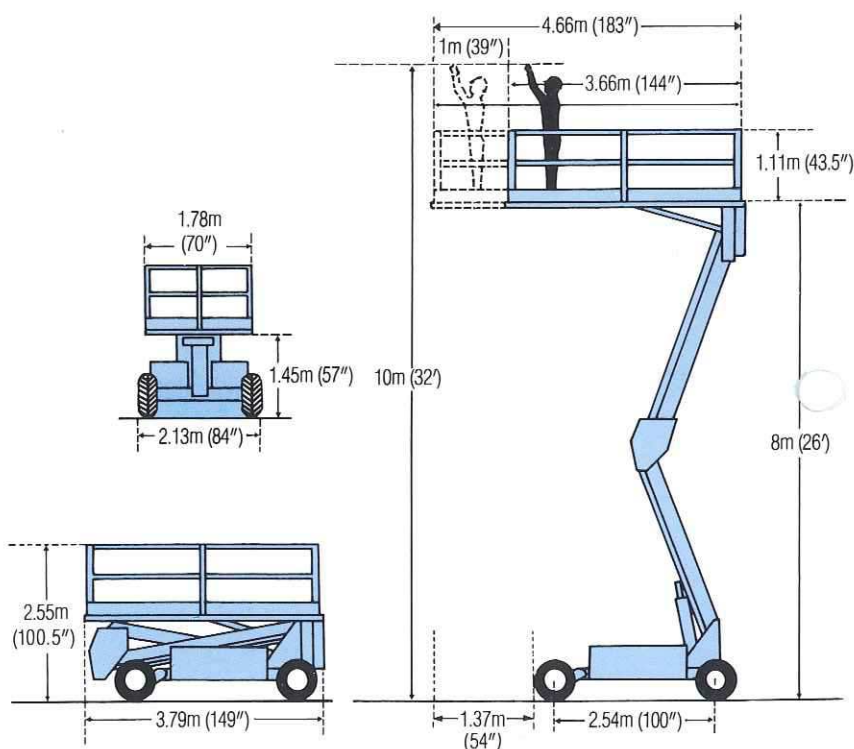

UpRight

EUROPE (353) 1 - 2853333

Pottery Road, Dun Laoire, Ireland.

USA (800) 926-5438

1775 Park St., Selma, CA 93662.

CANADA (800) 461-4901

108 Industrial Dr., Whitby, Ontario, Can L1N5Z8.